

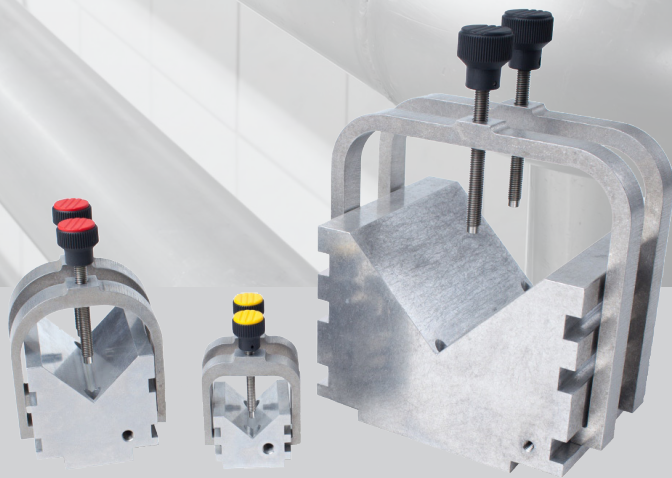

Clamping Prisms Accessories



For more
information
please visit
our website:



www.orbitalservice.de

Clamping Prisms

Accessories

As auxiliary tools for the orbital welding, Orbitalservice GmbH manufactures a set of tacking- and centering-devices. The tacking- and clamping-prisms are supplied in three different variations. The raw material is high-strength aluminium. The securing- or clamping-straps were cut with a water-jet. The threaded spindles are made of stainless steel. In addition the prisms have bores with reductions. E. g. for the direct fixing on a work bench. The prisms and the notches for the clamping-straps are clearly recognizable and marked with the application-area of these.

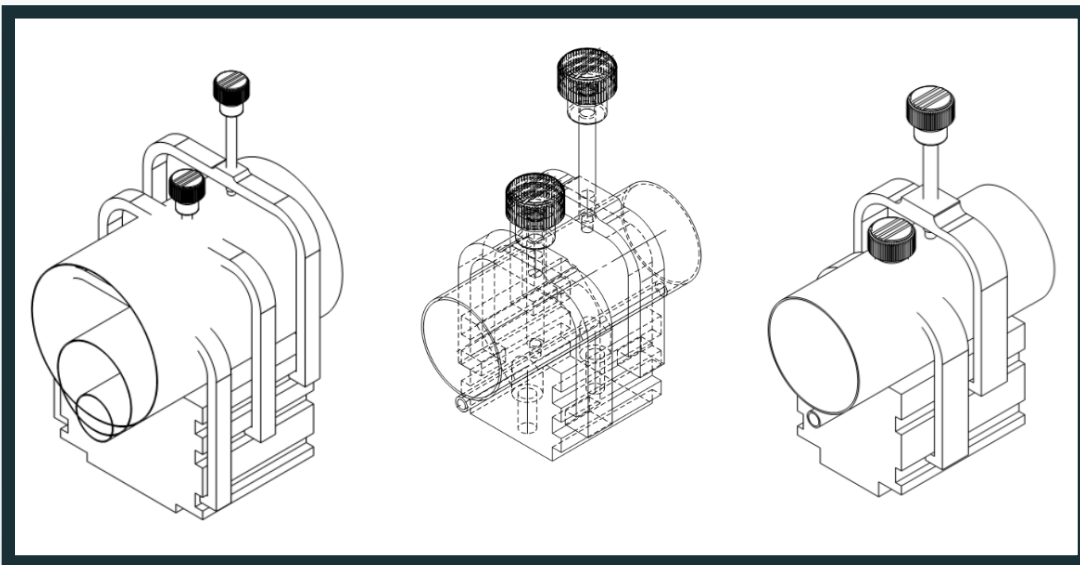

DATA //

Model	Area of application	Prism size (LxWxH)	Weight of the prism
Prism 40	6 mm - 40 mm	50 x 50 x 40	0,4 kg
Prism 70	10 mm - 70 mm	95 x 80 x 77	1,8 kg
Prism 170	50 mm - 170 mm	150 x 192 x 141	11,5 kg

For more information please visit our website:



ORBITALSERVICE GmbH • Kreuzdelle 13 • D-63872 Heimbuchenthal

✉ info@orbitalservice.de

🌐 www.orbitalservice.de

☎ +49 (0) 6092 82294 0

📞 +49 (0) 6092 82294 09